



energy
saxony

MORE ENERGY TOGETHER

The Energy Cluster for Saxony

MEMBERS

Number of members	75
SMEs	48
Large companies	10
Research organisations / Universities / Technology centres	16
Economic political players	2

as of 16/08/2021



WORKING GROUPS

In the interdisciplinary working groups, energy-related issues are investigated on the initiative of members and projects are initiated and implemented.

hydrogen
in industry
& business **H₂**



DBI GUT
Gas- und Umwelttechnik GmbH

Dr.-Ing. Stephan Anger

energy-
efficient
production 



Fraunhofer
IWU

Mark Richter

storage
and grid
services 



SKELE+ON
TECHNOLOGIES

Dr. Sebastian Pohlmann

resources,
recycling
& energy 



PIC - Pi Innovation
Culture GmbH

Romann Glowacki **Dr. Christina Peters**

energy
solutions for
buildings 



BA BERUFSAKADEMIE SACHSEN
STAATLICHE STUDIENAKADEMIE
GLAUCHAU
UNIVERSITY OF COOPERATIVE EDUCATION

Dr. Claudia Kandzia

heating
and
cooling 



Hochschule
Zittau/Görlitz
UNIVERSITY OF APPLIED SCIENCES

Prof. Dr.-Ing. habil. Tobias Zschunke

energy
technology
components 



TECHNISCHE
UNIVERSITÄT
DRESDEN

Hochschule
Zittau/Görlitz
UNIVERSITY OF APPLIED SCIENCES

Prof. Dr.-Ing. Steffen Großmann **Prof. Dr.techn. Stefan Kornhuber**

CLUSTER SERVICES

Events



Policy Dialogue



Trade Fairs



Projects



Newsletter



Marketing



Energy Saxony members are supported according to their individual needs:

- **NETWORKING:**
Matchmaking and business partnering
- **MARKETING**
Promotion of our members' products, services and events
- **SALES PROMOTION:**
Information on market trends, innovation support, science transfer, initiation of projects
- **REPRESENTATION OF INTERESTS:**
Dialogue with political decision-makers, funding acquisition



HZWO INNOVATION CLUSTER

Saxon Value Creation Network for Fuel Cell
and Hydrogen Technology



Saxon Innovation Cluster for Fuel
Cells and Hydrogen Technology

Component development
for fuel cell vehicles

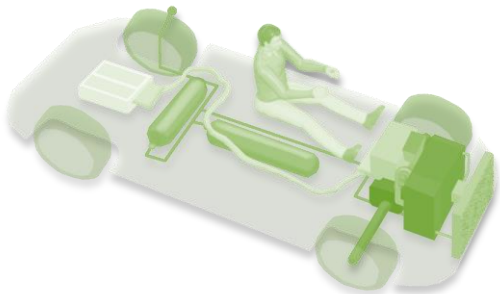

Establishment of a supply
infrastructure for green hydrogen

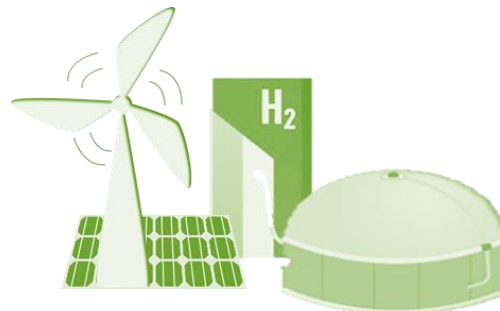

FUNDING PROGRAM:
„INNOVATION CLUSTERS SAXONY“
STAATSMINISTERIUM
FÜR WIRTSCHAFT
ARBEIT UND VERKEHR |  Freistaat
SACHSEN

Funding period: 2018 - 2021
Funding amount: 1.6 mio. €
Funding rate: 50 %

Innovation Cluster HZwo



Sächsischer Innovationscluster
für Brennstoffzellen und Wasserstoff



This measure is co-financed by tax funds on the basis of the budget adopted by the members of the Saxon Parliament.

Projects

- **Gas distribution net:** study regarding a transformation path to 100% H₂
- **Steel and chemical industry:** concept study for H₂ distribution in Meißen county
- **Dresden:** Lighthouse project combining electrolysis, filling station, buses

HIC – Hydrogen and Mobility Innovation Center

Wir sind einer von vier Standorten und bekommen 60 Mio. €





Fakten und Zahlen

- 37.000 m² auf Technologie-Campus in Chemnitz
- 600 ha in der Region
- direkte Anbindung an die universitäre, städtische und fernlogistische Infrastruktur
- grüne Wasserstoffversorgung ist bereits konzipiert
- Nähe zu Teststrecken für Straßen- und Schienenfahrzeuge

Dekra
Lausitzring

SRCC-
Bahntest-
strecke

Satelliten

TU
Dresden

Weitere
Kooperieren
de
Unternehmen



Technische Schwerpunkte

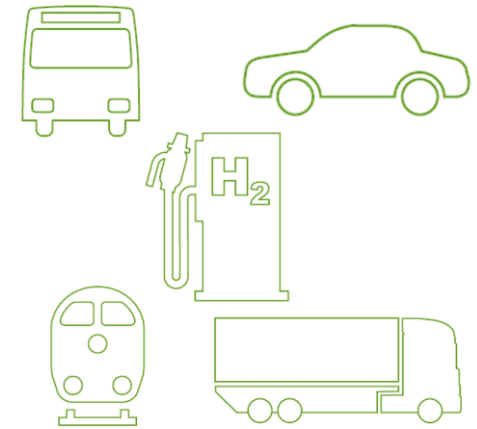
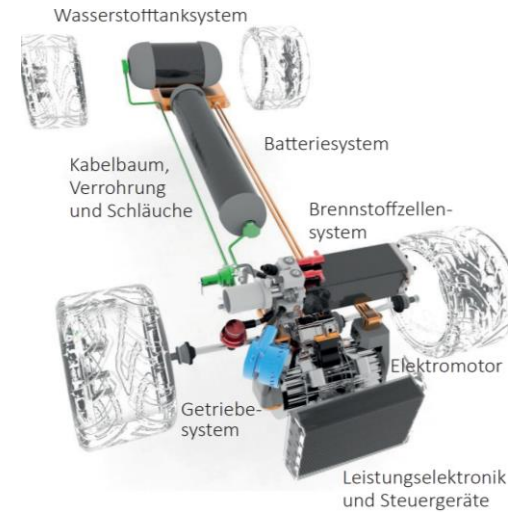
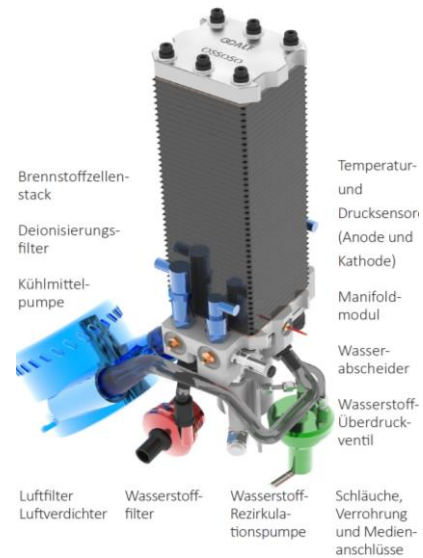
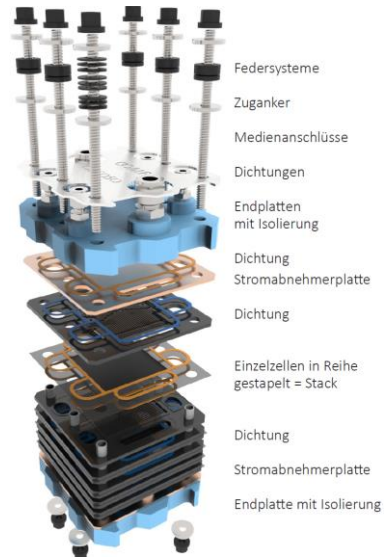

einschließlich BoP-Komponenten, H₂-Tanksystem, Integration, Betriebsstrategien, Software, Betankung

HyExperts Bewerbung Wasserstoff-Modellregion Chemnitz

HyExperts
Wasserstoff-Modellregion Chemnitz

Sektorenkopplung und Einsatz bestehender EE-Anlagen für Mobilität, Forschung und Wärme, in der Automobil- und Strukturwandelregion Chemnitz

Wasserstoffbedarf für Mobilität, Forschung und Wärme

Bestehende Erneuerbare Energieanlagen nutzen

Wirtschaftsregion Chemnitz mit 1,5 Millionen Einwohnern

13.09.21
Zuschlag
erhalten



HyExperts Bewerbung

Akteursnetzwerk der H₂-Region Chemnitz



HZWO FAIR



Planned for Q3 | 2022 at Messe Dresden

Saxon trade fair for suppliers of hydrogen and fuel cell technologies with congress and supporting programme

Contact

Cluster Management



**Lukas
Rohleder**
Managing Director

☎ +49 (0)171 2806608
✉ rohleder@energy-saxony.net



**Christiane
Demmler**
Cluster Services

☎ +49 (0)351 79 65 110
✉ demmler@energy-saxony.net

Board



**Mandy
Schipke**
NOVUM



**Dr. Frank
Arnold**
SachsenEnergie



**Dr. Mareike
Wolter**
Fraunhofer IKTS



**Dietmar
Lauter**
WISAG



**Prof. Tobias
Zschunke**
HSZG